



30W BRIDGE CAR RADIO AMPLIFIER

- NO AUDIBLE POP DURING MUTE AND STANDBY OPERATIONS
- MUTING TTL COMPATIBLE
- VERY LOW STANDBY CONSUMPTION
- PROGRAMMABLE TURN ON DELAY
- DIFFERENTIAL INPUT
- SHORT CIRCUIT PROTECTIONS:
RL SHORT - OUT TO GROUND - OUT TO V_S
- OTHER PROTECTIONS:
 - Load dump voltage surge
 - Loudspeaker DC current
 - Very inductive load
 - Overrating temperature
 - Open ground



DESCRIPTION

The TDA7256 is a class AB fully protected bridge power amplifier, designed for car radio applica-

tions. The high current capability allows to drive low impedance loads (up to 2Ω). The differential inputs availability makes it particularly suitable for boosters and active loudspeakers applications.

BLOCK DIAGRAM

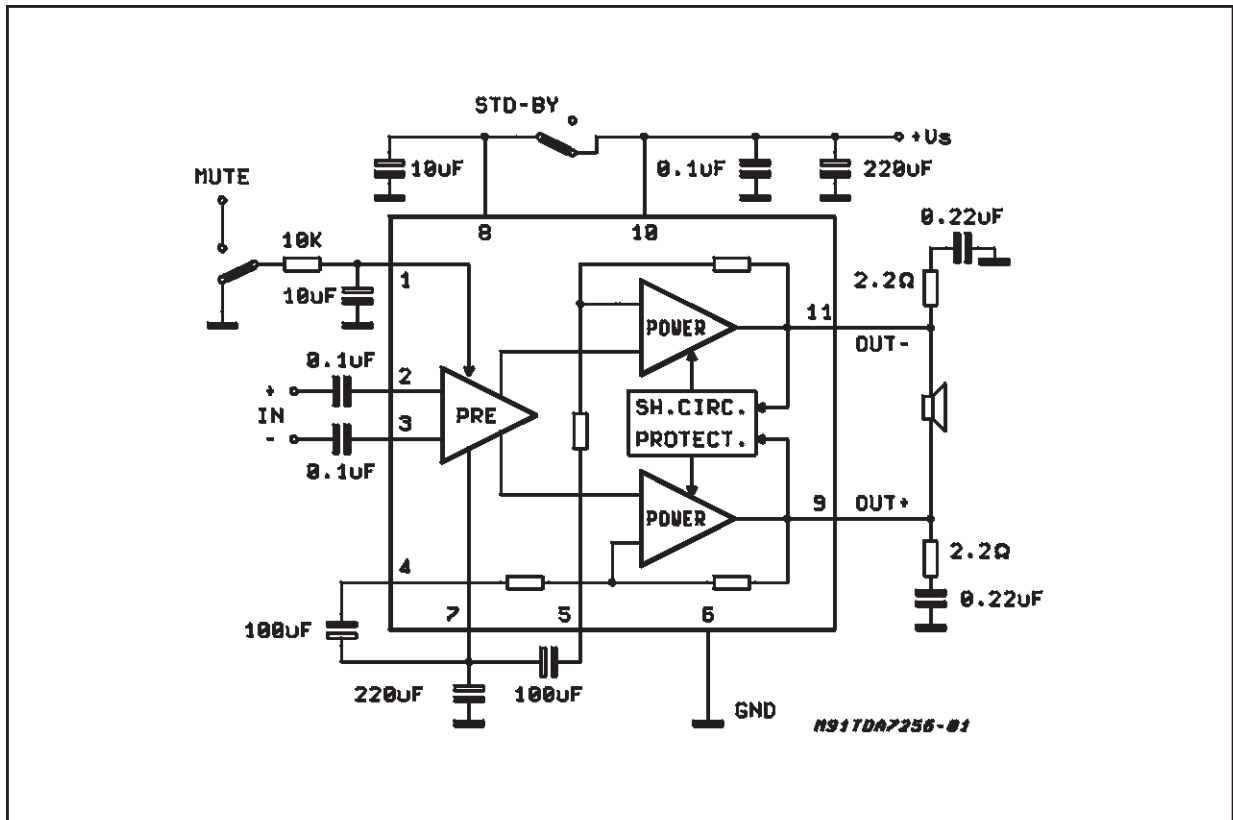

PIN CONNECTION (Top view)

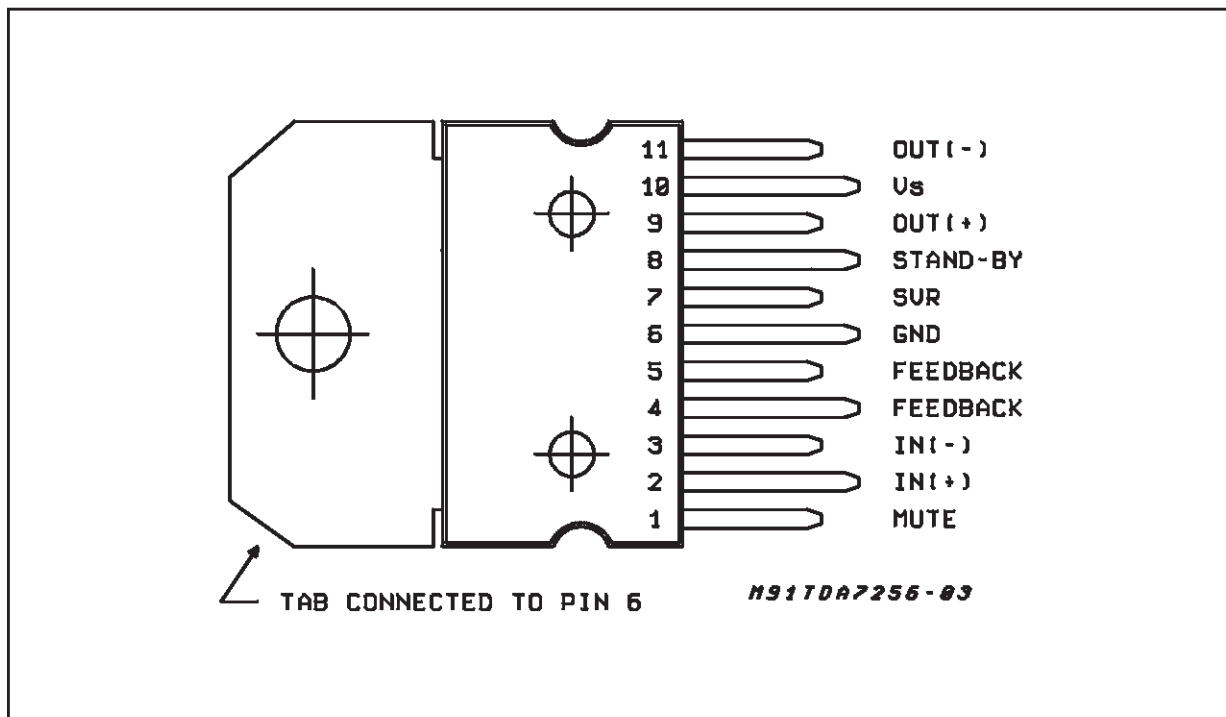

ABSOLUTE MAXIMUM RATINGS

Symbol	Parameter	Test Conditions	Unit
V_S	Operating Supply Voltage	18	V
V_S	DC Supply Voltage	28	V
V_S	Peak Supply Voltage (for 50ms)	40	V
I_o	Output Peak Current (non repetitive $t = 0.1ms$)	internally limited	
I_o	Output Peak Current Repetitive $f > 10Hz$	5.5	A
P_{tot}	Power Dissipation ($T_{case} = 85^{\circ}C$)	36	W
T_{stg}, T_J	Storage and Junction Temperature Range	-40 to +150	$^{\circ}C$

THERMAL DATA

Symbol	Description	Value	Unit
$R_{th\ j-case}$	Thermal Resistance Junction-case	Max 1.8	$^{\circ}C/W$

ELECTRICAL CHARACTERISTICS ($V_S = 14.4V$, $R_L = 4\Omega$, $f = 1KHz$; $T_{amb} = 25^\circ C$, unless otherwise specified)

Symbol	Parameter	Test Condition	Min.	Typ.	Max.	Unit
V_S	Supply Voltage		8		18	V
I_q	Quiescent Drain Current			80	150	mA
R_i	Input Resistance		50			K Ω
CMR	Common Mode Rejection	$f = 1KHz$, $V_{in} = 100mV$		60		dB
V_{OS}	Output Offset Voltage				150	mV
P_o	Output Power	$d = 10\%$ $R_L = 4\Omega$ $R_L = 3.2\Omega$ $R_L = 2\Omega$	18	22 26 30		W W W
d	Distortion	$P_o = 0.1W$ to $13W$		0.05	0.5	%
G_V	Voltage Gain (CL)			36		dB
e_N	Total Input Noise Voltage	$R_g = 10K\Omega$, $B = 22Hz$ to $22KHz$		3	10	μV
SVR	Supply Voltage Rejection	$R_g = 10K\Omega$, $V_r = 1V_{rms}$, $f = 300Hz$	45	60		dB
	Muting Attenuation	$V_{ref} = 1V_{rms}$, $f = 100Hz$ to $10KHz$	60			dB
	Muting-in Threshold Voltage	Pin 1	2.4			V
	Muting-out Threshold Voltage	Pin 1			0.8	V
	Stand-by Attenuation	$V_{ref} = 1V_{rms}$	60			dB
	Stand-by Current Consumption				100	μA
T_{SD}	Thermal Shut-down Junction Temperature			145		$^\circ C$

Figure 1: Test and Application Circuit

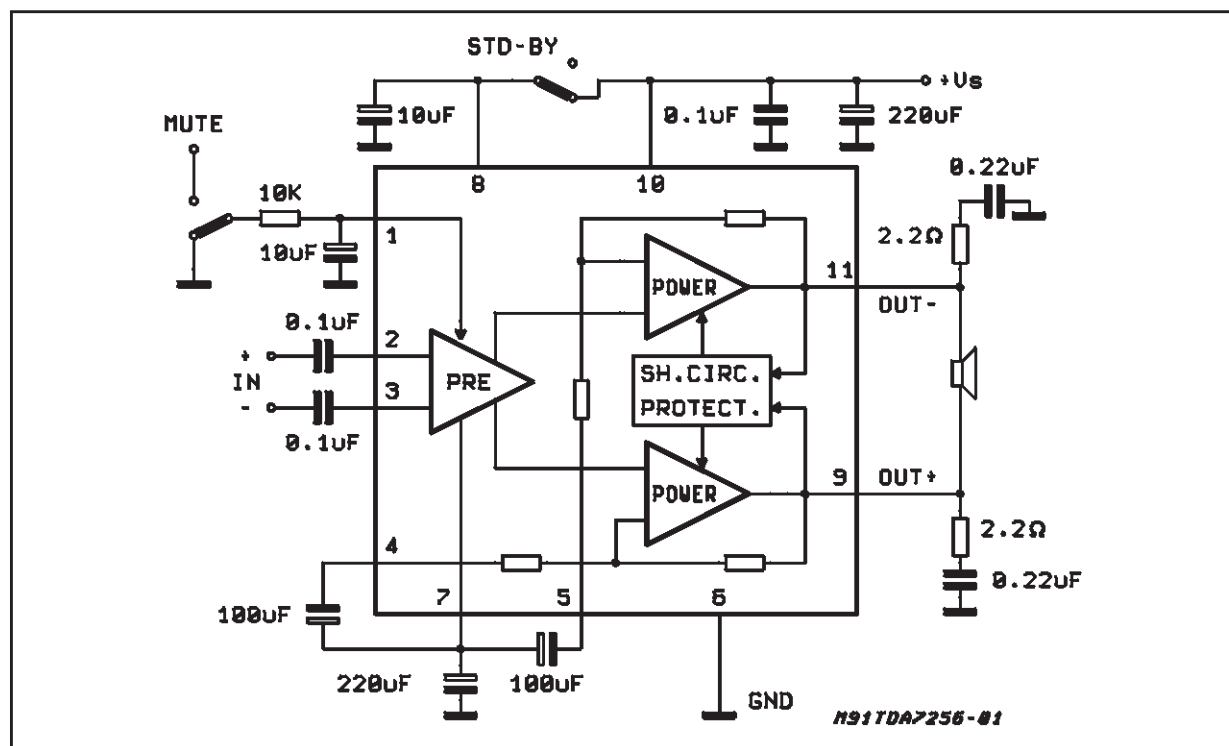

Figure 2: P.C. and Layout of the fig.1 (1:1 scale)

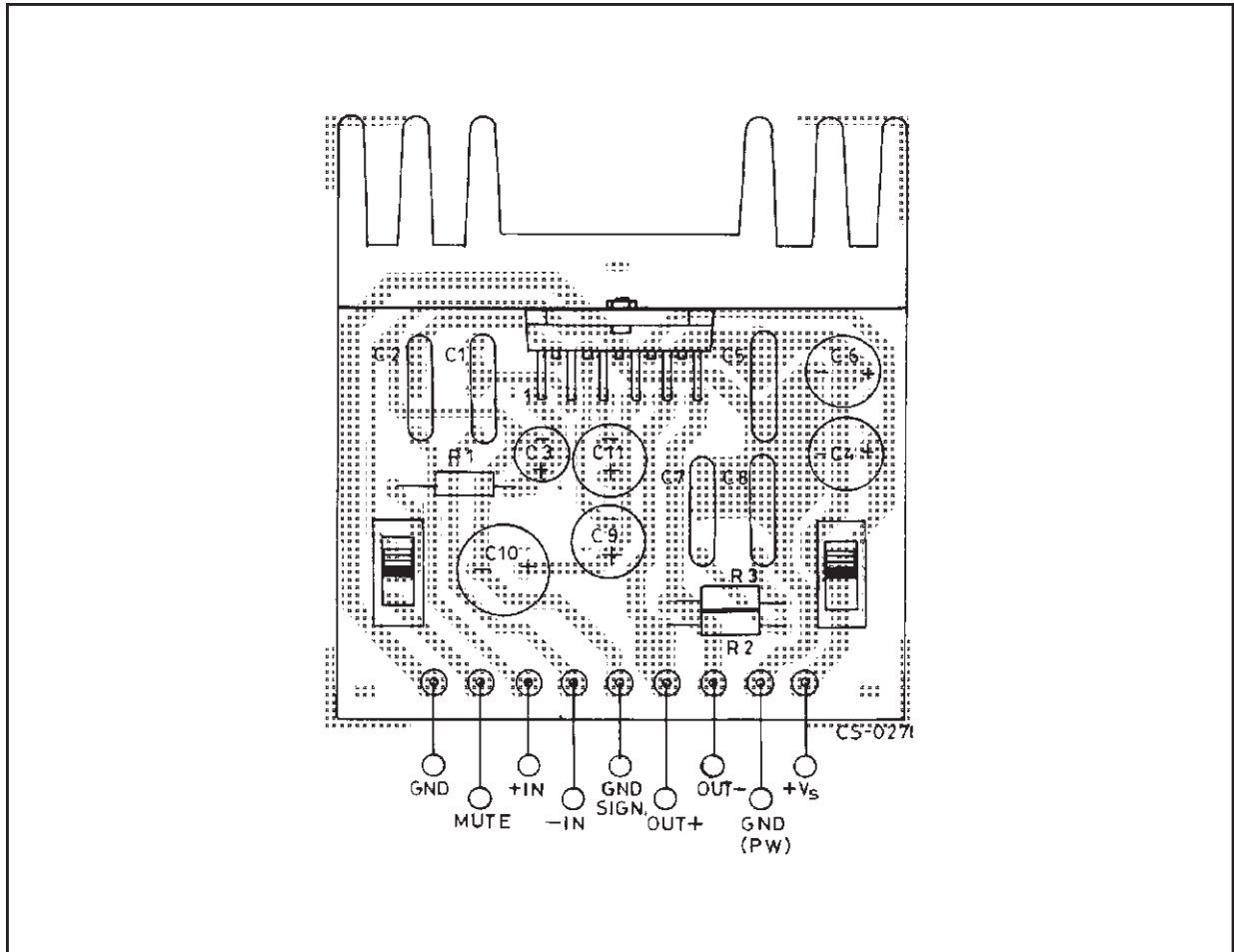

Figure 3: Drain Current vs. Supply Voltage

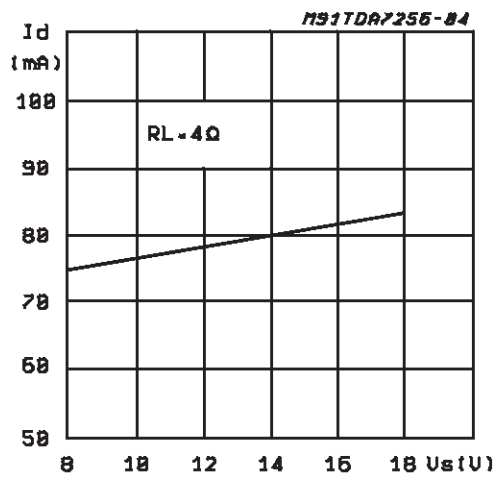

Figure 4: Output Power vs. Supply Voltage

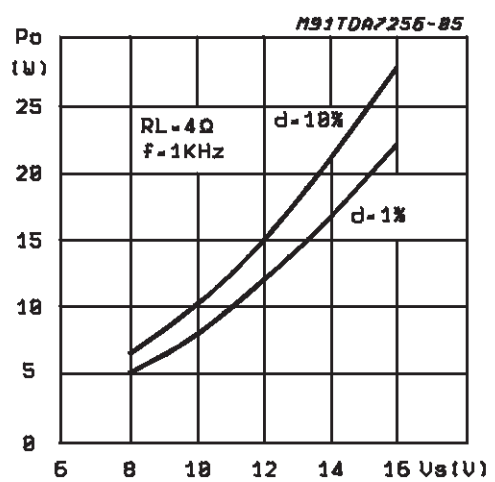

Figure 5: Output Power vs. Supply Voltage

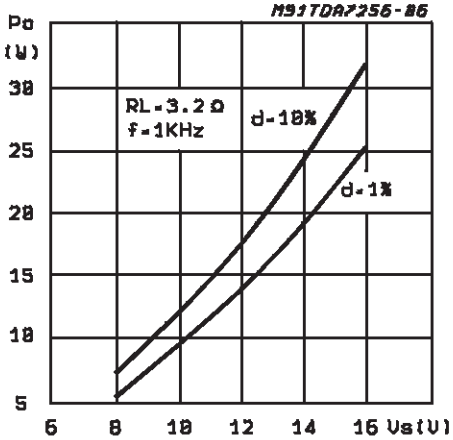

Figure 6: Output Power vs. Supply Voltage

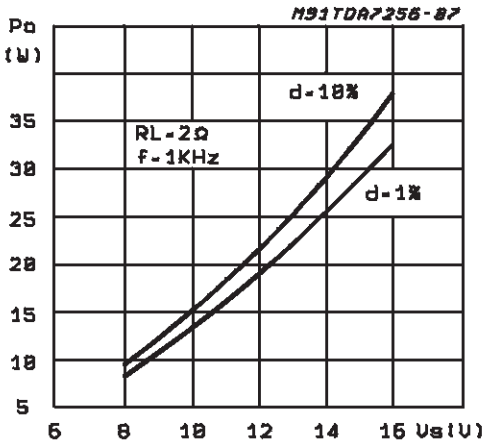

Figure 7: Distortion vs. Output Power

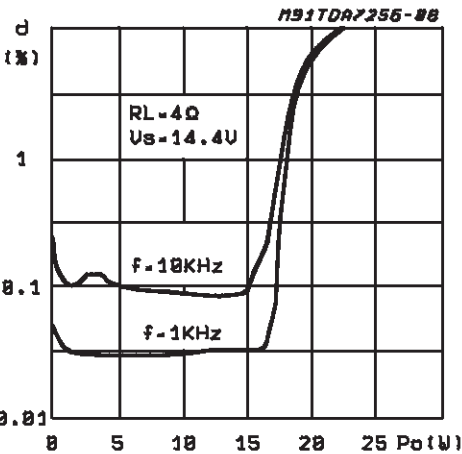

Figure 8: Distortion vs. Output Power

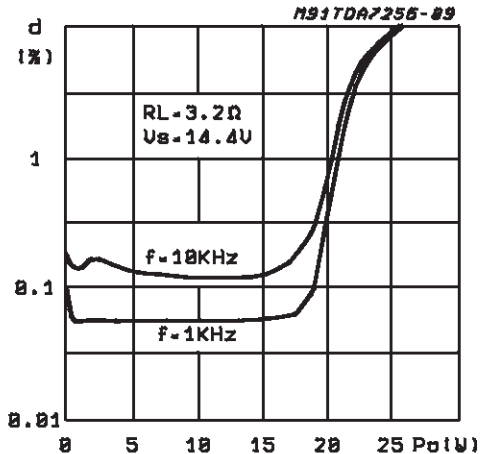

Figure 9: Distortion vs. Output Power

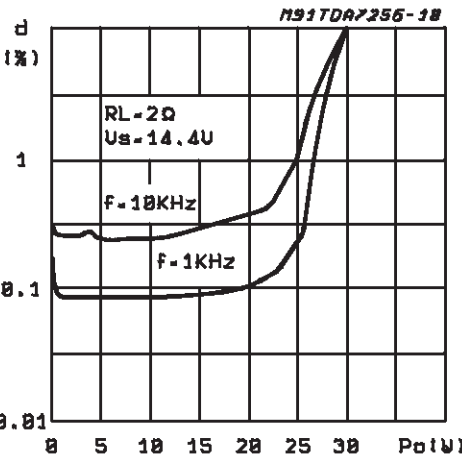

Figure 10: Distortion vs. Frequency

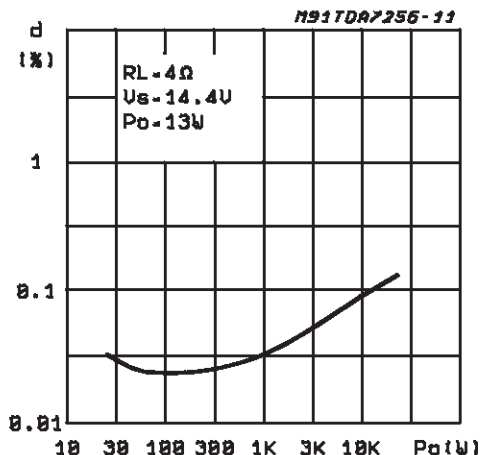

Figure 11: Distortion vs. Frequency

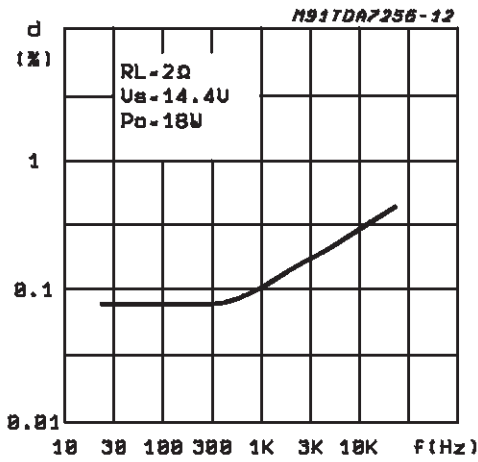

Figure 12: SVR vs. Frequency

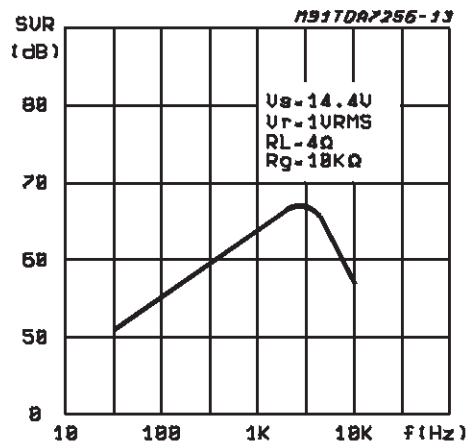

Figure 13: CMRR vs. Frequency

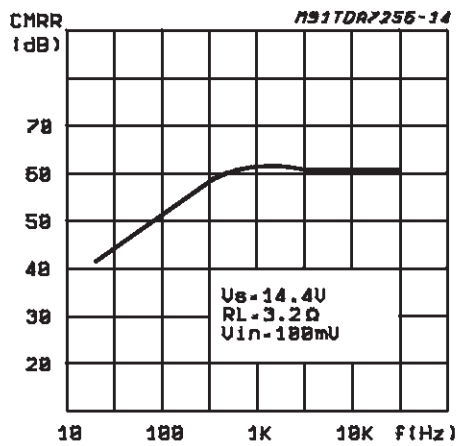

Figure 14: Power Dissipation & Efficiency vs. Output Power

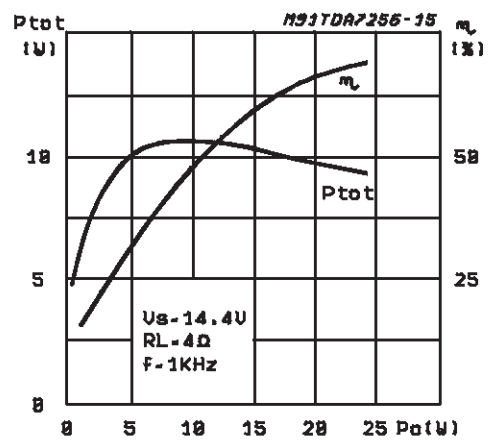

Figure 15: Power Dissipation & Efficiency vs. Output Power

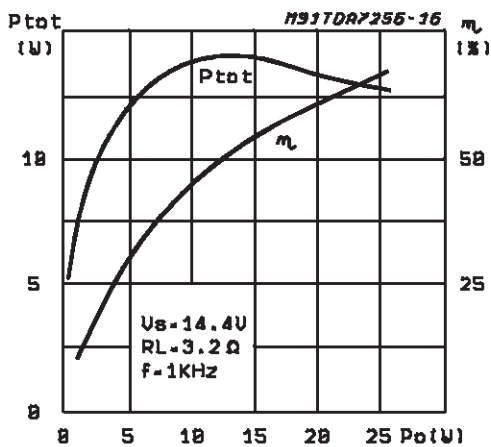
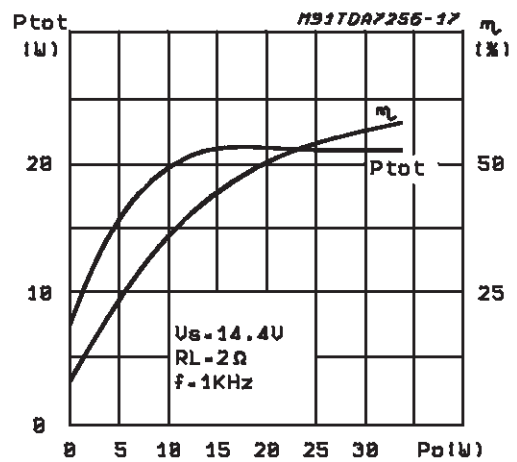

Figure 16: Power Dissipation & Efficiency vs. Output Power



CIRCUIT DESCRIPTION

INPUT STAGE

The input stage is a differential type preamplifier stage with two independent inputs and two outputs in phase opposition.

It is designed for particular linearity characteristics in order to have output amplitude large enough (1VPP) yet maintaining low distortion.

The voltage gain of the stage is 6 dB. The possibility to use the differential input allows the system immunity to common-mode noise in case of long wire connections (fig. 17)

Figure 17: Balanced -Unbalanced Input

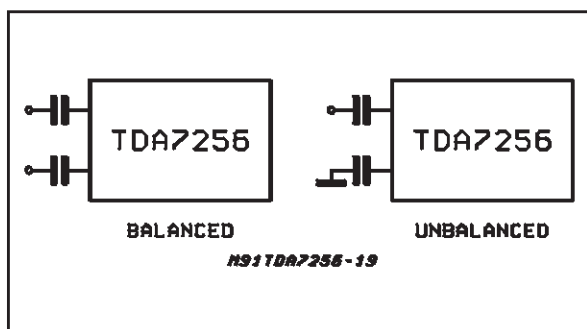

MUTE

The mute circuit (TTL compatible) acts at preamplifier level and disables the inputs without changing the DC voltage values. In such a way the operation is fully popless. The use of a RC network produces a soft reduction of the audio signal providing the best effect from the acoustic point of view (fig 18).

The mute circuit is also activated during turn-on/turn-off operations when the voltage at standby pin is lower than about 2 volt

Figure 18: Soft Muting

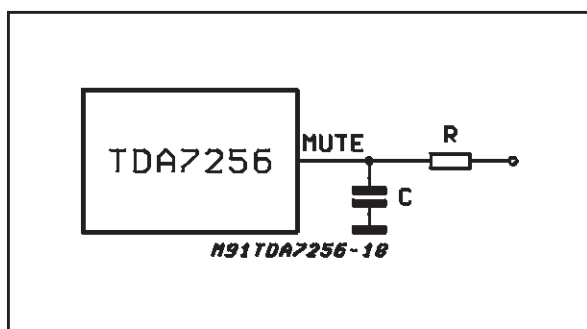

TURN-ON

The TDA7256 is fully popless at turn-on thanks to a delay circuit which keeps the output low during the capacitors charge transient.

The delay-time is given by the following formula:

$$T_o = 800 C_{10} + 600 (C_9 + C_{11}) \left(\frac{C_{10}}{C_9 + C_{11}} + 1 \right)$$

TURN-OFF

The ground compatible structures and the choice of a soft turn-off circuit ensure a fully popless operation.

OUTPUT STAGE

It is a power stage designed in a way of being able to drive loads up to 2 ohm in bridge configuration without bootstrap capacitors (22 W with $R_L=4$ ohm, 30W with $R_L=2$ ohm).

SVR

The noises coming from the car environment are essentially inside the bandwidth from 300 Hz to 6 KHz.

The ripple rejection circuit which utilizes also the gain capacitors C11, C9 ensures in this frequency range a rejection typ. of 60dB.

SHORT CIRCUIT PROTECTION

The short circuit protection circuits intervene in the following cases:

- s.c. between one output and ground
- s.c. between one output and +Vs
- s.c. between the outputs

In the first two cases they stop the current in both the final stages, allowing also loudspeaker protection. In the last case the current is limited, thus avoiding the load point to reach the SOA of the output transistors.

STAND-BY

In stand-by condition the current generators are disabled: the current drops to a very low value (few μ A). Also this function is fully popless.

Fig. 19 shows the silent transients of turn-on and turn-off operations through both the mute and the stand-by pins.

Figure 19: Silent Transients Through the Mute and Stand-by pins.

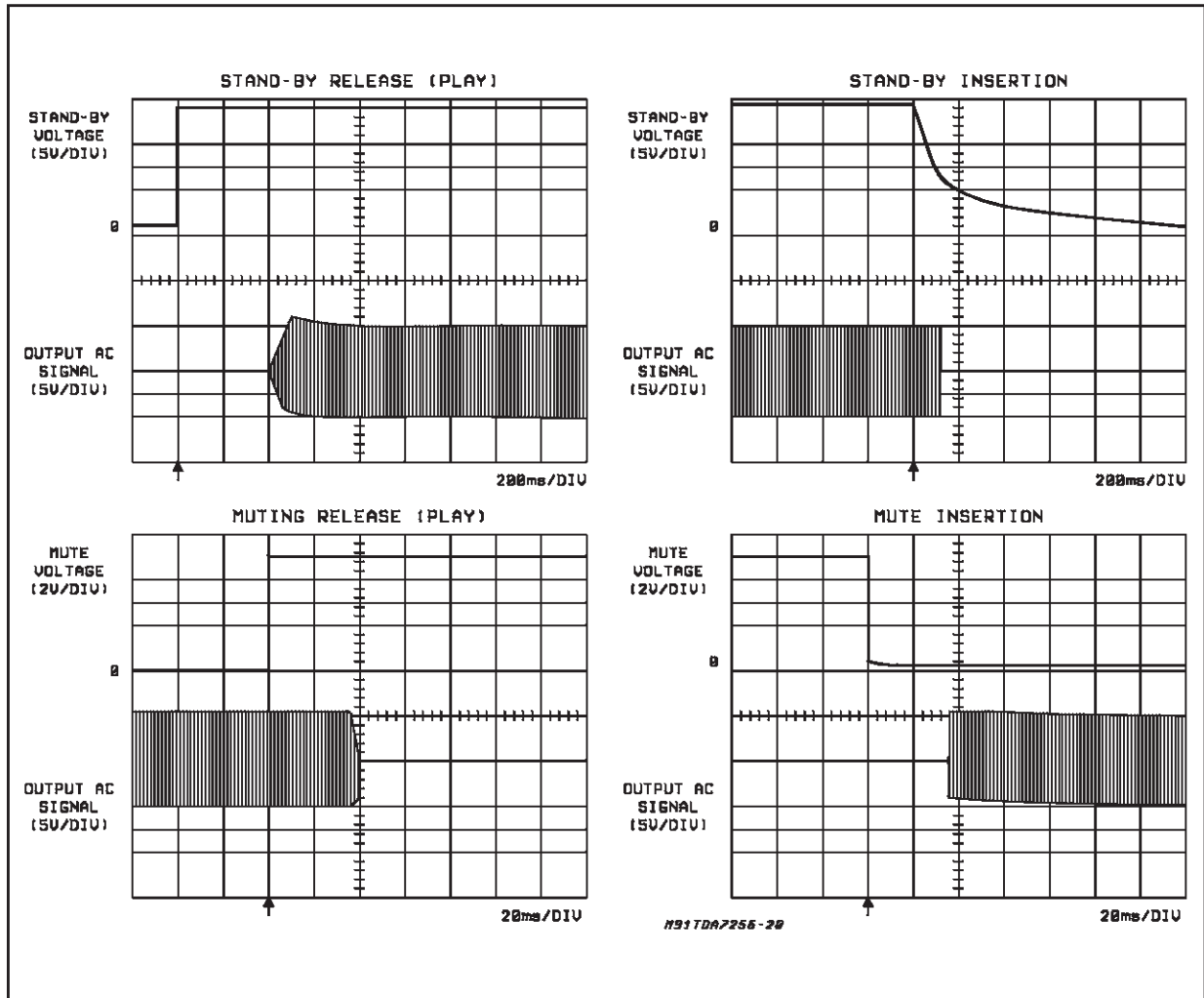

DIM.	mm			inch		
	MIN.	TYP.	MAX.	MIN.	TYP.	MAX.
A			5			0.197
B			2.65			0.104
C			1.6			0.063
D		1			0.039	
E	0.49		0.55	0.019		0.022
F	0.88		0.95	0.035		0.037
G	1.45	1.7	1.95	0.057	0.067	0.077
G1	16.75	17	17.25	0.659	0.669	0.679
H1	19.6			0.772		
H2			20.2			0.795
L	21.9	22.2	22.5	0.862	0.874	0.886
L1	21.7	22.1	22.5	0.854	0.87	0.886
L2	17.4		18.1	0.685		0.713
L3	17.25	17.5	17.75	0.679	0.689	0.699
L4	10.3	10.7	10.9	0.406	0.421	0.429
L7	2.65		2.9	0.104		0.114
M	4.25	4.55	4.85	0.167	0.179	0.191
M1	4.73	5.08	5.43	0.186	0.200	0.214
S	1.9		2.6	0.075		0.102
S1	1.9		2.6	0.075		0.102
Dia1	3.65		3.85	0.144		0.152

OUTLINE AND MECHANICAL DATA

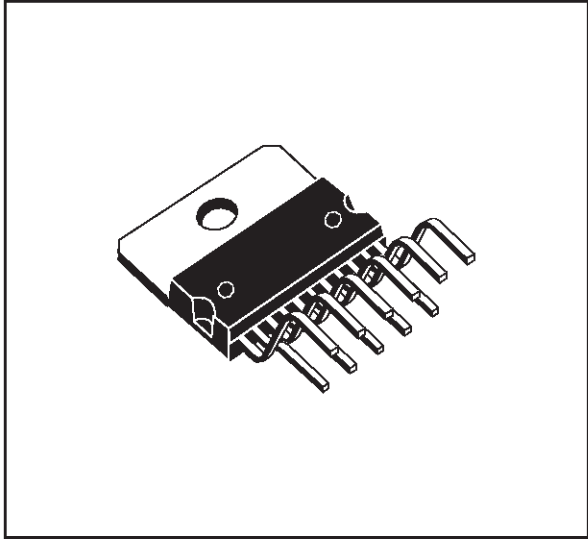

Multiwatt11 V

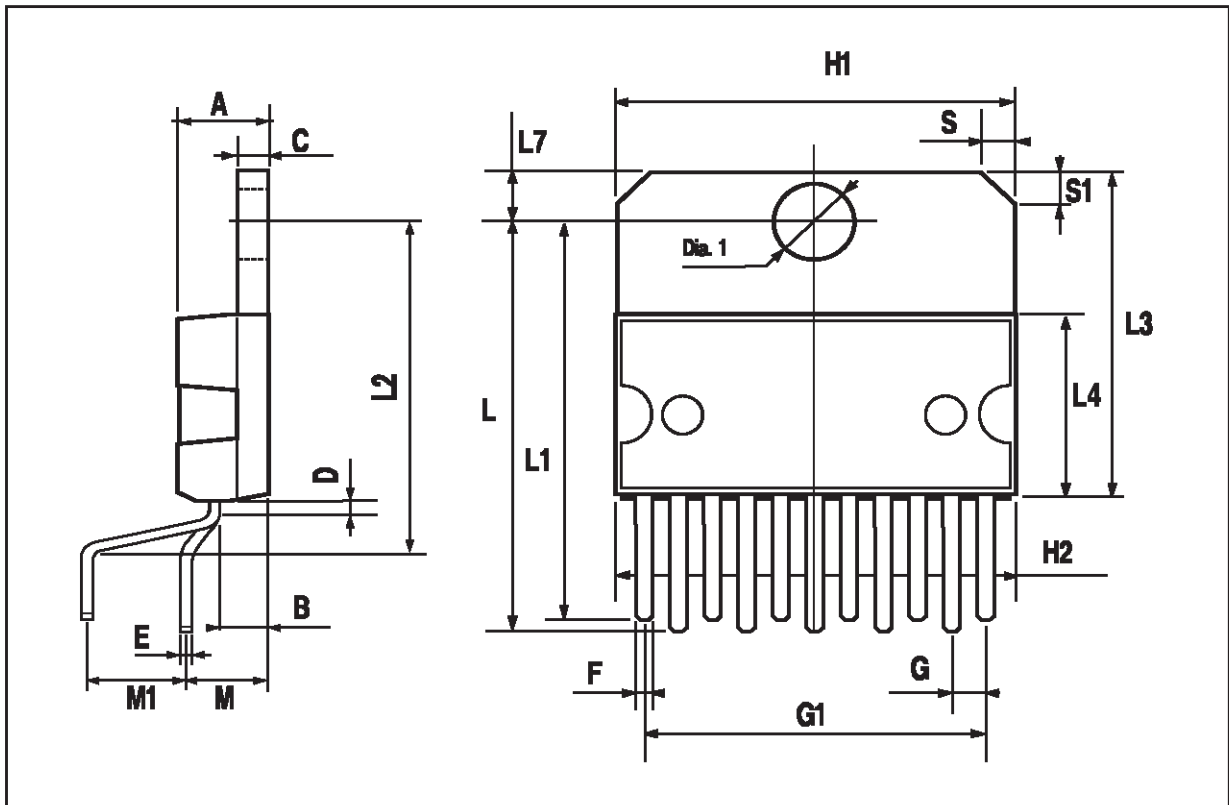

Information furnished is believed to be accurate and reliable. However, SGS-THOMSON Microelectronics assumes no responsibility for the consequences of use of such information nor for any infringement of patents or other rights of third parties which may result from its use. No license is granted by implication or otherwise under any patent or patent rights of SGS-THOMSON Microelectronics. Specifications mentioned in this publication are subject to change without notice. This publication supersedes and replaces all information previously supplied. SGS-THOMSON Microelectronics products are not authorized for use as critical components in life support devices or systems without express written approval of SGS-THOMSON Microelectronics.

© 1995 SGS-THOMSON Microelectronics - All Rights Reserved
MULTIWATT® is a Registered Trademark of SGS-THOMSON Microelectronics

SGS-THOMSON Microelectronics GROUP OF COMPANIES
Australia - Brazil - France - Germany - Hong Kong - Italy - Japan - Korea - Malaysia - Malta - Morocco - The Netherlands - Singapore -
Spain - Sweden - Switzerland - Taiwan - Thailand - United Kingdom - U.S.A.